

5065T

Product



KRAMER
on the safe side



simple operation, compact design and manoeuvrability

The new 5 Series models feature simple operation, compact design and manoeuvrability. The Kramer 5065T is equipped with the unrivalled Kramer system and alongside the telescoping loading system enables a greater reach and stacking height. The 5065T achieves a stacking height of up to 4 m and is optimally suitable for loading all vehicles licensed according to the StVZO (German Road Traffic Regulations). This telescopic wheel loader provides you with the Kramer benefits such as constant payload and stability due to its one-piece chassis and the all-wheel steering.

- Created for the routine: The optimal loading system setup ensures the best visibility of the attachment and the quickhitch plate
- Unbeatable manoeuvrability: 2,900 mm turning radius (tyre outer edge) realised by 2x38° steering locks
- Safety: The tilt back angle limit of 45° with maximum lifting height protects the operator and machine from undesired loss of materials
- Cost reducing: The efficient high-pressure drive system for low operating costs and high thrusting force
- Compact dimensions: The low overall height of under 2.5 m and the low vehicle width of under 1.65 m

enables simple and cost-effective transportation of the telescopic wheel loader

5065T Technical specifications

Operating data

Bucket capacity	0.65 m ³
Operating weight	4,350 kg

Engine / Motor

Engine / Motor manufacturer	Yanmar
Emission standards stage (standard)	V

Power transmission

Traction drive	Continuously variable, hydrostatic axial piston transmission
Driving speed (standard)	20 km/h
Driving speed (option)	27 km/h
Standard tires	12.0-18
Differential lock	100 % front
Max. steering angle	2 x 38 °

Steering and operating hydraulics

Max. pump discharge capacity	50 l/min
Max. pump pressure	240 bar
Max. Powerflow discharge capacity	90 l/min

Kinematics

Design system	Z-Kinematics
Tipping load with standard bucket	2,500 kg
Payload (S=1.25)	1,650 kg
Tilt-in angle	30 °
Tip-out angle	40 °

Filling capacities

Fuel tank	60 l
Hydraulic oil tank	58 l

Sound emission

Measured value	100 dB(A)
Guaranteed value	101 dB(A)
Noise level at the driver's ear	84 dB(A)

Vibrations

Total vibrations value of the upper body extremities	<8.2 feet/s ²
Highest effective value of weighted acceleration for the body	<1.64 feet/s ²

All statements without guarantee.

Additional technical data is available in the detailed brochure in the informational material section.

5065T Dimensions

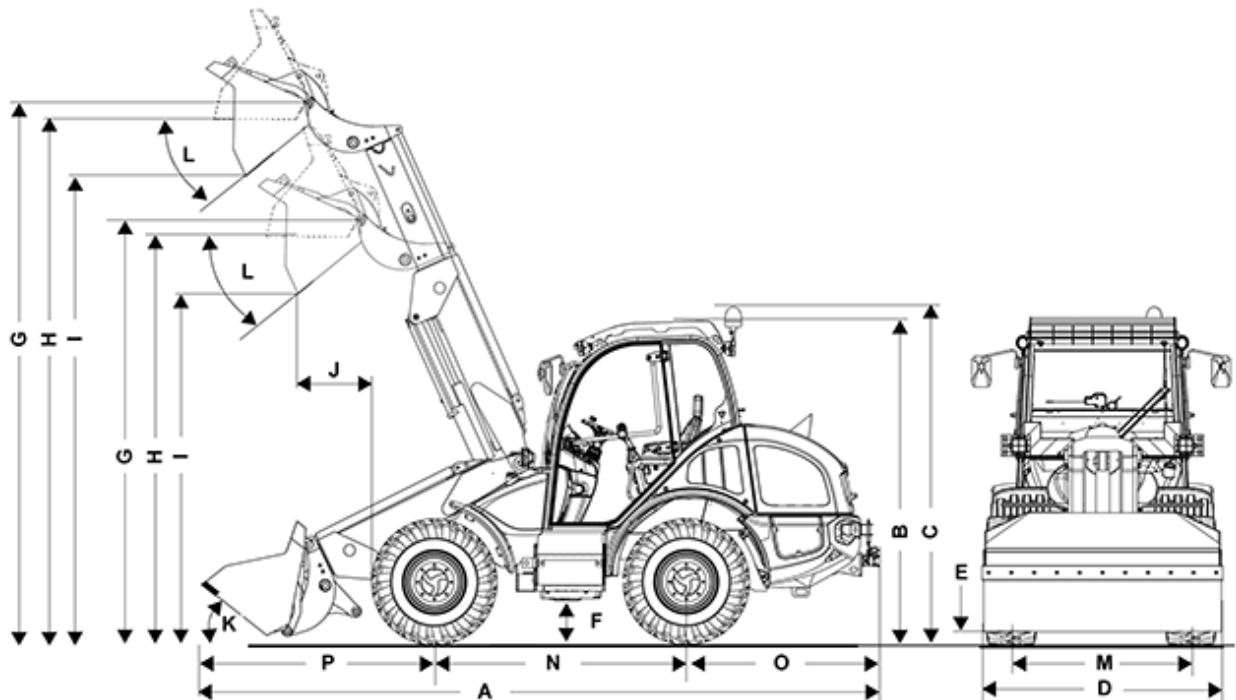

A	Length	5,350 mm
B	Height	2,470 mm
C	Total height with rotating beacon	2,670 mm
D	Width	1,590 mm
E	Ground clearance in transport position of the loading installation	250 mm
F	Ground clearance under axle and gearbox	280 mm
G	Bucket pivot point - retracted	3,420 mm
G	Bucket pivot point - extended	4,270 mm
H	Overhead loading height - retracted	3,160 mm
H	Overhead loading height - extended	4,010 mm
I	Dumping height - retracted	2,650 mm
I	Dumping height - extended	3,500 mm
J	Dump reach - retracted	560 mm
J	Dump reach - extended	810 mm
K	Tilt-in angle	30 °
L	Tip-out angle	40 °
M	Track width	1,262 mm
N	Wheelbase	2,000 mm
O	Center of rear axle to end of vehicle	1,320 mm
P	Center of front axle to tip of teeth	1,992 mm

Bucket width	1,650 mm
Stack height (arm extended)	4,030 mm
Turning radius over tyres	2,900 mm

Please note: that product availability can vary from country to country. It is possible that information / products may not be available in your country. More detailed information on engine power can be found in the operator's manual; the stated power may vary due to specific operating conditions. Subject to alterations and errors excepted. Applicable also to illustrations.

Copyright © 2021 Kramer-Werke GmbH.