

# 8145T

## Product



**KRAMER**  
*on the safe side*



### Stacking made easy with the new telescopic wheel loader

Kramer will offer the 8145T with telescopic loader unit and Z-kinematics in the range of the 9 - 11 ton class. The telescopic wheel loader has a bucket tipping load of 5,500 kilograms, a stacking payload of 3,900 kilograms and an impressive operating weight of 11,170 kilograms. Beside application areas in industry and recycling, the 8145T can be used for material transport on large construction sites as well as for loading and unloading heavy transport chains and carriers. The different attachments are always perfectly visible thanks to the compact modular design of the loader unit. The Z-kinematics provide higher tearout forces and particularly quick emptying of shovels.

- Strong performance: 100 kW powerful Deutz TCD 3.6 L4 engine or optional 115 kW Deutz TCD 4.1 L4 engine
- Innovatively designed cabin: the ergonomically arranged operator's controls and the excellent all-round visibility provide for fatigue-free and efficient working.
- Variable hydrostatic transmission: ecospeedPRO for the speed range up to 40 km/h, including Smart Driving (optional)
- Powerful load-sensing hydraulics: 150 l/min or optional 180 l/min allows for fast work cycles
- Intelligent air flow and reversible fan motor: High cooling performance with little maintenance effort,

since no dust is swirled up due to the air flow

## 8145T Technical specifications

### Operating data

Bucket capacity	1.45 m <sup>3</sup>
Operating weight	11,170 kg

### Engine / Motor

Engine / Motor manufacturer	Deutz
Engine performance (standard)	100 kW
Engine performance (option)	115 kW
Emission standards stage (standard)	V

### Power transmission

Traction drive	Automotive continuously variable, hydrostatic axial piston drive
Driving speed (standard)	20 km/h
Driving speed (option)	30 km/h
Driving speed (option)	40 km/h
Standard tires	500/70R24 Michelin BIBLOAD
Differential lock	100 % front axle + rear axle
Max. steering angle	2 x 40 °

### Steering and operating hydraulics

Max. pump discharge capacity	150 l/min
Max. pump pressure	250 bar
Max. Powerflow discharge capacity	180 l/min

### Kinematics

Design system	Z-kinematics
Tipping load	5,500 kg
Payload	3,900 kg
Tilt-in angle	43 °
Tip-out angle	40 °

### Filling capacities

Fuel tank	140 l
Hydraulic oil tank	125 l
DEF tank	12 l

### Sound emission

Measured value	101 dB(A)
Guaranteed value	103 dB(A)
Noise level at the driver's ear	70 dB(A)

### Vibrations

Total vibrations value of the upper body extremities	< 2.5 m/s <sup>2</sup>
Highest effective value of weighted acceleration for the body	< 0.5 m/s <sup>2</sup>

## 8145T Dimensions

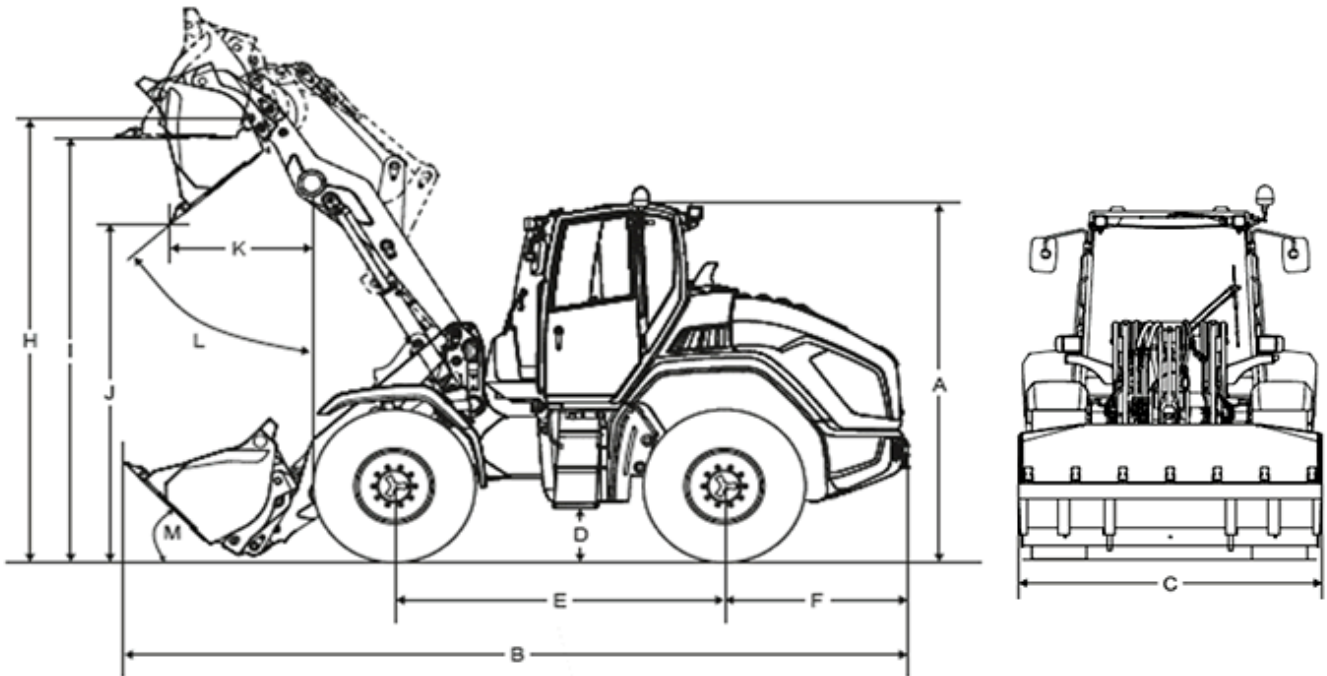

Length	7,020 mm
Height	3,010 mm
Width	2,500 mm
Bucket pivot point - extended	5,425 mm
Overhead loading height - retracted	5,185 mm
Dumping height - retracted	4,470 mm
Dump reach - retracted	1,655 mm
Tilt-in angle	40 °
Tip-out angle	40 °
Center of rear axle to end of vehicle	1,520 mm
Stack height (arm extended)	5,190 mm
Turning radius over tyres	3,865 mm

Please note: that product availability can vary from country to country. It is possible that information / products may not be available in your country. More detailed information on engine power can be found in the operator's manual; the stated power may vary due to specific operating conditions. Subject to alterations and errors excepted. Applicable also to illustrations.

Copyright © 2021 Kramer-Werke GmbH.