

2706

Telehandlers < 6 m



KRAMER
on the safe side



Efficient compact design

The most compact Kramer telehandler 2706 has a lift capacity of 2.7 t and a stacking height of 6 m. The telehandler is driven by a Kohler engine with 75 HP. As standard, this machine is equipped with a DOC (diesel oxidation catalytic converter) and a DPF (diesel particle filter), which works in a fuel-saving and powerful manner. The electronic balanced joystick performs quick work cycles as various movements are carried out simultaneously.

- Lift capacity: 2.7t payload and a stacking height of 6m
- Economical consumption: Economical consumption and high torque with DOC and DPF
- Kramer quickhitch plate: The robust design enables a quick change of tools within a few seconds
- Compactness: Compact dimensions enable efficient work in confined environments, such as underground car parks
- Operating concept: The Kramer operating concept with the electronically operated all-in-one joystick allows for an intuitive operation of all functions

2706 Technical specifications

Operating data

Max. stack height	6,000 mm
Max. payload	2,700 kg
Operating weight	5,000 kg
Bucket capacity	0.85 m ³
Lift height	5,730 mm
Turning radius	3,670 mm
Steering angle	2x38 °

Engine / Motor

Engine / Motor manufacturer	Kohler
Type / Model	KDI 2504 TCR
Engine performance	55.4 kW
Emission standards stage	V
Exhaust aftertreatment system	DOC+DPF

Power transmission

Traction drive	Hydrostatic
Travel speed max	20 km/h
Travel speed optional	30 km/h
Differential lock	100% connectable
Service brake	hydraulic disc brake
Standard tires	12.5-18 MPT01

Operating hydraulics

Max. pump discharge capacity	90 l/min
Max. pump pressure	240 bar

Filling capacities

Fuel tank	100 l
Hydraulic oil tank	75 l

Sound emission

Measured value	103 dB(A)
Guaranteed value	104 dB(A)
Noise level at the driver's ear	80 dB(A)

Vibrations

Total vibrations value of the upper body extremities	< 2,5 m/s ² (< 8.2 feet/s ²)
Highest effective value of weighted acceleration for the body	- < 0,5 m/s ² (< 1.64 feet/s ²)

All statements without guarantee.

Payload at max. lift height: with hydraulic leveling

Stacking height at max. payload: with hydraulic leveling

Sound emission: The measurement occurs according to the requirements of the EN 1459 standard and the 2000/14/EC directive. Measuring area: asphalted surface

Vibrations: Uncertainty of measurement as specified in ISO/TR 25398:2006. Please instruct or inform the operator of possible hazards from vibrations.

Vibrations: Total vibrations value of the upper body extremities: on level and secure ground driving appropriately

Vibrations: Highest effective value of weighted acceleration for the body: use in extraction under harsh environmental conditions

2706 Dimensions

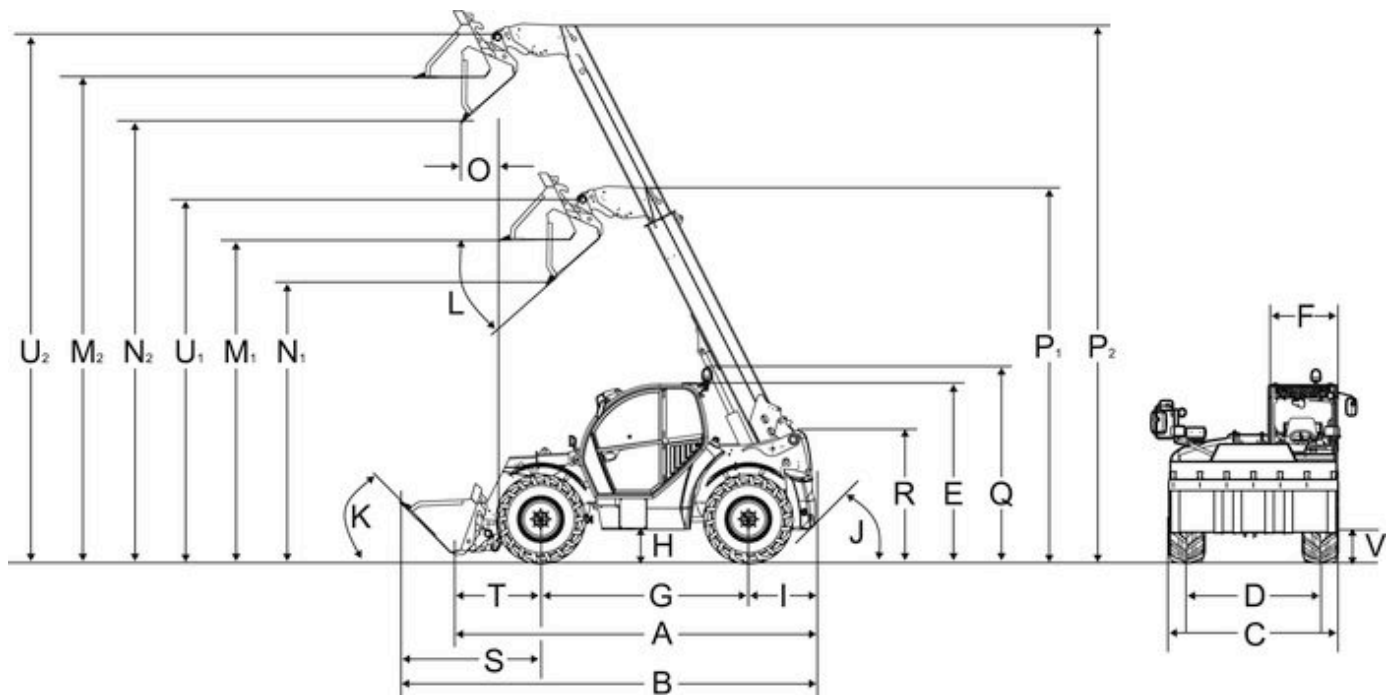

A	Overall length	4,400 mm
B	Overall length with bucket	5,000 mm
C	Overall width without attachment	1,960 mm
D	Track width front	1,660 mm
D	Track width rear	1,660 mm
E	Total height	1,980 mm
F	Cabin width	825 mm
G	Wheelbase center	2,650 mm
H	Ground clearance under axle and gearbox	302 mm
J	Rear actuation angle	76 °
I	Distance center of rear wheel to rear	720 mm
K	Tipping angle	45 °
L	Tip-out angle	22 °
M1	Overhead loading height - retracted	3,730 mm
M2	Overhead loading height - extended	5,600 mm
N1	Dumping height - retracted	3,450 mm
N2	Dumping height - extended	5,280 mm
O	Dump reach - extended	680 mm
P1	Length	4,420 mm
P2	Length	6,260 mm
Q	Total height with rotating beacon	2,210 mm
R	Total height of the telescopic arm bearing in the frame	1,415 mm
S	Distance from the front wheel center to the front edge of the bucket	1,840 mm
T	Distance from the center of the bearing of the front wheel to the quick-change frame	1,840 mm
U1	Bucket pivot point - retracted	4,240 mm

U2	Bucket pivot point - extended	6,080 mm
V	Transport position with attachment	175 mm
-	Turning radius at the outer edge of the wheels	3,670 mm
-	Entry height, cabin floor	360 mm
-	Turning radius at the outer edge of the bucket	4,500 mm

All statements without guarantee.

Machine dimensions can vary depending on tyres.

'Total length' and 'Distance from center of rear wheel to the rear':

- with hitch coupling + 70 mm (KT276); + 320 mm (KT306, KT356, KT307, KT357, KT447, KT507, KT557); + 154 (KT559)

- with height adjustable ball hitch + 320 mm (KT306, KT356, KT307, KT357, KT447, KT507, KT557)

- with fixed ball hitch + 200 mm (KT306, KT356, KT307, KT357, KT447, KT507, KT557)

'Total width without bucket' with standard bucket 5 depending on the tyres, with folded-in mirrors

'Rear approach angle (departure angle)' with ball hitch 51° (KT276); 32° (KT306, KT356, KT307, KT357)

Please note: that product availability can vary from country to country. It is possible that information / products may not be available in your country. More detailed information on engine power can be found in the operator's manual; the stated power may vary due to specific operating conditions. Subject to alterations and errors excepted. Applicable also to illustrations.

Copyright © 2021 Kramer-Werke GmbH.